

**Titre:** Path-tracking control for a tractor-trailer via input-output  
Title: linearization

**Auteurs:** Romano M. De Santis  
Authors:

**Date:** 1997

**Type:** Rapport / Report

**Référence:** De Santis, R. M. (1997). Path-tracking control for a tractor-trailer via input-output linearization. (Rapport technique n° EPM-RT-97-18).  
Citation: <https://publications.polymtl.ca/10090/>

 **Document en libre accès dans PolyPublie**  
Open Access document in PolyPublie

**URL de PolyPublie:** <https://publications.polymtl.ca/10090/>  
PolyPublie URL:

**Version:** Version officielle de l'éditeur / Published version

**Conditions d'utilisation:** Tous droits réservés / All rights reserved  
Terms of Use:

 **Document publié chez l'éditeur officiel**  
Document issued by the official publisher

**Institution:** École Polytechnique de Montréal

**Numéro de rapport:** EPM-RT-97-18  
Report number:

**URL officiel:**  
Official URL:

**Mention légale:**  
Legal notice:

20 JUIN 1997

**PATH-TRACKING CONTROL FOR A TRACTOR-TRAILER  
VIA INPUT-OUTPUT LINEARIZATION**

**Romano M. DeSantis**

**Mai 1997**

*gratuit*

**Tous droits réservés. On ne peut reproduire ni diffuser aucune partie du présent ouvrage, sous quelque forme ou par quelque procédé que ce soit, sans avoir obtenu au préalable l'autorisation écrite des auteurs.**

**Dépôt légal, Mai 1997  
Bibliothèque nationale du Québec  
Bibliothèque nationale du Canada**

**Path-Tracking Control for a Tractor-Trailer  
Via Input-Output Linearization**

**Romano M. DeSantis  
Département de Génie Électrique et  
Génie Informatique**

**Pour se procurer une copie de ce document, s'adresser au:**

**Service des Éditions  
École Polytechnique de Montréal  
Case postale 6079, Succursale Centre-Ville  
Montréal (Québec) H3C 3A7  
Téléphone: (514) 340-4473  
Télécopie: (514) 340-3734**

**Compter 0,10\$ par page et ajouter 3,00\$ pour la couverture, les frais de poste et la manutention. Régler en dollars canadiens par chèque ou mandat-poste au nom de l'École Polytechnique de Montréal.**

**Nous n'honorons que les commandes accompagnées d'un paiement, sauf s'il y a eu entente préalable dans le cas d'établissements d'enseignement, de sociétés ou d'organismes canadiens.**

28 APRIL, 1997

# PATH-TRACKING CONTROL FOR A TRACTOR-TRAILER VIA INPUT-OUTPUT LINEARIZATION

DeSantis, R.M., Professor, E & C Eng Dpt,  
Ecole Polytechnique de Montréal  
2900, boul. Edouard-Montpetit, CP 6079-A  
Montreal, Quebec, Canada, H3C 3A7

## 1. Summary

The exact linearization approach to design path-tracking controllers for wheeled vehicles is generalized to make it applicable to a larger class of vehicles. This larger class includes a tractor-trailer with 'off-axle' hitching, a bi-articulated bus for express intercity travel, and a load-haul-dump mining truck. Distinctive features of the proposed generalization are the adoption of input-output rather than input-state linearization and (most importantly) the selection of a vehicle's guide-point dependent on whether path-tracking has to be implemented in the forward direction or in reverse. Preliminary simulation results suggest the attainment of controllers that are better performing than otherwise obtainable on the basis of the available techniques.

**Keywords:** motion-control, path-tracking, articulated vehicles, tractor-trailer, exact linearization, input-output linearization, on-axle hitching, off-axle hitching, absence of slippage.

## 2. Introduction

Considerable efforts are presently being devoted to provide wheeled vehicles with autonomous or semi-autonomous motion (see, for example, Giralt 1988, Cox and Wilfong 1990, Shin et al. 1992, Baiden and Henderson 1994). One of the problems to be considered in carrying out this endeavour is the determination of tractor's speed and steering that make a selected guide-point of the vehicle track an assigned path with a desired velocity. Finding a solution to this problem is equivalent to designing a stabilizing controller for a complex, underactuated, nonlinear, intercoupled and, on occasion, time-variant and only partially known, dynamic plant (D'Andrea Novel et al. 1992, Laumond 1993, Walsh et al. 1994, Samson 1995, Sampei et al. 1995, Hilrose et al. 1995, Sordalen and Egeland 1995).

In a previous study on articulated vehicles (DeSantis 1994) we developed a design procedure for path-tracking controllers that is based on the notion of geometric path-tracking and on the classical technique of tangent (Jacobian) linearization. In what follows, we revisit our procedure by replacing tangent with exact state-feedback linearization (Isidori 1995, Marino and Tomei 1996). As suggested in most of the cited references, an exact linearization approach to path-tracking is attractive because of its potential to lead to better performing and better understood controllers that are conceptually simpler to design and whose stability can be assured over a wider range of operating conditions.

A difficulty with the present status of the exact linearization approach to path-tracking for wheeled vehicles, however, is that it is confined to car-like vehicles, or to tractor-trailer-like vehicles with 'on-axle' hitching (the joint hitching a trailer to the remainder of the vehicle is located at the center of the rear axle of the preceding trailer or tractor). As a consequence, design procedures based on exact linearization are only applicable to vehicles belonging to one of the above two categories (Bolzern et al. 1997). Industrial examples of vehicles for which these procedures do not apply are represented by a tractor-trailer with 'off-axle' hitching (DeSantis 1994), a load-haul-dump mining truck (Juneau and Hurteau 1994, Kumar and Vagenas 1994, Lane and King 1994), a biarticulated bus for express intercity travel (Rabinovitch and Leitman 1996), or an industrial lawn mower (Larsson et al. 1994). In theory, one should be able to deal with this latter kind of vehicles by adopting the novel 'Flat systems' approach proposed by Fliess et al. 1995. In practice, while research on the subject is still active, the required mathematical manipulations appear so formidable as to make it unclear whether such an approach would indeed lead to a solution of the problem.

The objective of the present paper is to overcome this difficulty by generalizing the available exact linearization procedures for the design of path-tracking controllers. For simplicity of exposition, we proceed by considering as prototype of the wheeled vehicles of interest a tractor-trailer with off-axle

hitching and by adopting the mathematical formulation of geometric path-tracking. With little loss of generality, we confine our development to circular or straightline paths to be tracked with a constant speed. In agreement with most of the existing literature, we concentrate attention on the kinematic model of the vehicle.

### 3. Vehicle's Model

Consider a tractor with two rear-drive and two front-steering wheels, linked to a trailer with two rear wheels by means of a vertical joint. Following common practice, we view longitudinal speed and steering of the tractor as control variables to be manipulated so that a selected guide-point of the vehicle follows a desired path with an assigned velocity. A key feature of our development is a selection of guide-point that depends on the direction of motion. When path-tracking has to be implemented in the forward direction we locate the guide-point of the vehicle at the center of the rear axle of the tractor (as in DeSantis 1994); when path-tracking has to be implemented in reverse, we locate the guide-point at the center of the rear axle of the trailer (as in most of the other cited references).

With the notations in Figure 1 (see also list of symbols), and under the usual hypotheses of a planar and slippage-free motion, the vehicle's model is described by the following proposition. The first part of this proposition (eqns 3.1-3.6) is rather standard (Ellis 1969); the second part (eqns 3.7-3.14) is an equivalent reformulation

of the first; in the special case of 'on-axle' hitching ( $c=0$ ), this reformulation corresponds to the model adopted by most of the literature on the subject.

**Proposition 1 (Vehicle's model).** Under a slippage-free motion, the relation between tractor's speed and steering, and tractor-trailer's position and orientation is described by

$$\dot{x}_1 = v_{u1} \cos \theta_1 \quad (3.1)$$

$$\dot{y}_1 = v_{u1} \sin \theta_1 \quad (3.2)$$

$$\dot{\theta}_1 = \frac{v_{u1} \tan \delta}{l_1} \quad (3.3)$$

$$\dot{\phi} = - \frac{v_{u1}}{l_1 l_2} \{ l_1 \sin \phi + (l_2 + c \cos \phi) \tan \delta \} \quad (3.4)$$

$$\theta_2 = \phi + \theta_1$$

$$x_2 = x_1 - c \cos \theta_1 - l_2 \cos \theta_2 \quad (3.5)$$

$$y_2 = y_1 - c \sin \theta_1 - l_2 \sin \theta_2. \quad (3.6)$$

Equivalently, this relation is also described by

$$\dot{x}_2 = v_{u2} \cos \theta_2 \quad (3.7)$$

$$\dot{y}_2 = v_{u2} \sin \theta_2 \quad (3.8)$$

$$\dot{\theta}_2 = \frac{v_{u2} \tan(\beta - \phi)}{l_2} \quad (3.9)$$

$$\dot{\phi} = \frac{v_{u2}}{c l_2} \{ l_2 \sin \phi + (c + l_2 \cos \phi) \tan(\beta - \phi) \} \quad (3.10)$$

$$x_1 = x_2 + c \cos \theta_1 + l_2 \cos \theta_2 \quad (3.11)$$

$$y_1 = y_2 + c \sin \theta_1 + l_2 \sin \theta_2 \quad (3.12)$$



with

$$v_{u2} = v_{u1} \left( \cos\phi - \frac{c \tan\delta}{\ell_1} \sin\phi \right) \quad (3.13)$$

and

$$\beta := -\text{atan}(c \tan\delta / \ell_1). \quad (3.14)$$

#### 4. Path-Tracking Dynamics

A path-tracking assignment is described by a smooth vector function  $(x_p(s) \ y_p(s) \ \theta_p(s) \ \phi_p(s) \ v_{up}(s))$  designating position, orientation and speed that the vehicle should have at the point of the path defined by the curvilinear coordinate  $s \in (0, \infty)$ . As in DeSantis 1994,  $\phi_p(s)$  designates the orientation (relative to the tractor) that the trailer is required to have at  $s$ ;  $x_p(s) \ y_p(s) \ \theta_p(s) \ v_{up}(s)$  denote required position, orientation and longitudinal speed of the tractor or the trailer (depending on the location of the guide-point). We refer to  $(x_p(s) \ y_p(s))$ ,  $s \in (0, \infty)$ , as the Euclidean path and to  $v_{up}(s)$  as the velocity profile.

Given a path-tracking assignment, to a vehicle configuration and speed  $(x \ y \ \theta \ \phi \ v_u)$ , we associate speed  $(v_{os})$ , heading  $(\theta_{os}, \phi_{os})$ , and lateral  $(\ell_{os})$  path-tracking offsets defined by

$$\begin{aligned} v_{os} &:= v_u - v_{ud}, & \theta_{os} &:= \theta - \theta_d, & \phi_{os} &:= \phi - \phi_d, \\ \ell_{os} &:= -(x - x_d) \sin\theta_d + (y - y_d) \cos\theta_d, \end{aligned} \quad (4.1)$$

where

$$(x_d \ y_d \ \theta_d \ \phi_d \ v_{ud}) = (x_p(\lambda) \ y_p(\lambda) \ \theta_p(\lambda) \ \phi_p(\lambda) \ v_{up}(\lambda)). \quad (4.2)$$

The symbol  $\lambda$  (the distance traveled along the path) denotes the curvilinear coordinate of the point of the Euclidean path closest to  $(x \ y)$ . Path-tracking implies the determination of the tractor's speed,  $v_{ul}$ , and steering angle,  $\delta$ , that are required to have

$$\lim_{t \rightarrow \infty} [v_{os}(t) \ \theta_{os}(t) \ \phi_{os}(t) \ \ell_{os}(t)] = 0. \quad (4.3)$$

**Remark 1.** Similar to that considered by Sampei et al. 1995 and by Samson 1995, our formulation of (geometric) path-tracking becomes equivalent to the perhaps more traditional state-trajectory-following formulation by introducing the longitudinal path-tracking offset

$$\lambda_{os}(t) := \lambda(t) - \lambda_d(t). \quad (4.4)$$

Here,  $\lambda(t)$  and  $\lambda_d(t)$  denote actual and desired distance traveled along the path at time  $t \in [0, \infty)$ . Path-tracking can then be viewed as the task of generating the propulsion and steering controls that are necessary to have

$$\lim_{t \rightarrow \infty} [v_{os}(t) \ \theta_{os}(t) \ \Phi_{os}(t) \ \ell_{os}(t) \ \lambda_{os}(t)] = 0. \quad (4.5)$$

We embody the intended generalization of the exact linearization approach in the following propositions (proofs of which are in the appendix). Proposition 2 describes the time-evolution of the path-tracking offsets in correspondence with circular or straightline paths to be tracked with a constant velocity. Proposition 3 describe this same evolution as a function of distance traveled along the path. Propositions 4 and 5 provide the basis on which a path-tracking

controller can be designed using input-output linearization. In stating these propositions, we use the following convention: when path-tracking accuracy is measured in terms of position and orientation of the tractor (i.e. when the guide-point coincides with  $(x_1 \ y_1)$ ) we denote path-tracking offsets, distance traveled and curvature radius of the path with  $v_{os1}$   $\theta_{os1}$   $\phi_{os1}$   $l_{os1}$   $\lambda_1$  and  $R_1$ ; when measured by considering position and orientation of the trailer (the guide-point coincides with  $(x_2 \ y_2)$ ) we use the notations  $v_{os2}$   $\theta_{os2}$   $\phi_{os2}$   $l_{os2}$   $\lambda_2$  and  $R_2$  (see Figure 2).

**Proposition 2 (Path-tracking offsets dynamics as a function of time).** i) When

measured relative to the tractor, the dynamics of the path-tracking offsets is described by

$$\dot{l}_{os1} = v_{u1} \sin \theta_{os1} \quad (4.6)$$

$$\dot{\theta}_{os1} = v_{u1} \left\{ \frac{\tan \delta}{l_1} - \frac{\cos \theta_{os1}}{(R_1 + l_{os1})} \right\} \quad (4.7)$$

$$\dot{\phi}_{os1} = -v_{u1} \left\{ \frac{l_1 \sin \phi + (l_2 + c \cos \phi) \tan \delta}{l_1 l_2} \right\}, \quad (4.8)$$

where  $R_1$  is the radius of the circle to be followed by the guide-point on the tractor and  $\phi = \phi_d + \phi_{os1}$ , with  $\phi_d$  the solution of

$$R_1 \sin \phi_d + l_2 + c \cos \phi_d = 0.$$

ii) When the path-tracking offsets are measured relative to the trailer, their dynamics is described by

$$\dot{l}_{os2} = v_{u2} \sin \theta_{os2} \quad (4.9)$$

$$\dot{\theta}_{os2} = v_{u2} \left\{ \frac{\tan(\beta - \phi)}{l_2} - \frac{\cos \theta_{os2}}{R_2} \right\}$$

$$\theta_{os2} = v_{u2} \left\{ \frac{1}{l_2} - \frac{1}{(R_2 + l_{os2})} \right\}, \quad (4.10)$$

$$\dot{\phi}_{os2} = v_{u2} \left\{ \frac{l_2 \sin \phi + (c + l_2 \cos \phi) \tan(\beta - \phi)}{c l_2} \right\}, \quad (4.11)$$

where  $R_2$  is the radius of the circle to be followed by the guide-point on the trailer,  $\phi = \phi_d + \phi_{os2}$  with  $\phi_d$  as in eqn (4.8), and

$$\beta := -\text{atan}(c \tan \delta / l_1), \quad R_2 := R_1 \cos \phi_d - c \sin \phi_d. \quad (4.12)$$

**Proposition 3 (Path-tracking offsets dynamics as a function of distance traveled along the path).** Using the distance traveled along the path as time scale:

i) When measured relative to the tractor, the path-tracking offsets have the following dynamics

$$\frac{\partial l_{os1}}{\partial \lambda_1} = \text{sign}(v_{u1}) \frac{(R_1 + l_{os1})}{R_1} \tan \theta_{os1} \quad (4.13)$$

$$\frac{\partial \theta_{os1}}{\partial \lambda_1} = \text{sign}(v_{u1}) \left\{ \frac{(R_1 + l_{os1}) \tan \delta}{R_1 \cos \theta_{os1} l_1} - \frac{1}{R_1} \right\} \quad (4.14)$$

$$\frac{\partial \phi_{os1}}{\partial \lambda_1} = -\text{sign}(v_{u1}) \frac{(R_1 + l_{os1})}{R_1 \cos \theta_{os1}} \left\{ \frac{l_1 \sin \phi + (l_2 + c \cos \phi) \tan \delta}{l_1 l_2} \right\} \quad (4.15)$$

$$\dot{\lambda}_1 = \frac{R_1 \cos \theta_{os1}}{(R_1 + l_{os1})} v_{u1}. \quad (4.16)$$

ii) When measured relative to the trailer, their dynamics is described by

$$\frac{\partial l_{os2}}{\partial \lambda_2} = \text{sign}(v_{u2}) \frac{(R_2 + l_{os2})}{R_2} \tan \theta_{os2} \quad (4.17)$$

$$\frac{\partial \theta_{os2}}{\partial \lambda_2} = \text{sign}(v_{u2}) \left\{ \frac{(R_2 + l_{os2}) \tan(\beta - \phi)}{R_2 \cos \theta_{os2} l_2} - \frac{1}{R_2} \right\} \quad (4.18)$$

$$\frac{\partial \phi_{os2}}{\partial \lambda_2} = \text{sign}(v_{u2}) \frac{(R_2 + l_{os2})}{R_2 \cos \theta_{os2}} \left\{ \frac{l_2 \sin \phi + (c + l_2 \cos \phi) \tan(\beta - \phi)}{c l_2} \right\} \quad (4.19)$$

$$\dot{\lambda}_2 = \frac{R_2 \cos \theta_{os2}}{(R_2 + l_{os2})} v_{u2}. \quad (4.20)$$

**Proposition 4 (Chain-form representation of the Path-tracking offsets input-output dynamics).** i) When the path-tracking offsets are measured relative to the tractor, their input-output dynamics can be modeled by the following equations

$$\dot{x}_1 = u_1 \quad (4.21)$$

$$\dot{x}_2 = u_1 x_3 \quad (4.22)$$

$$\dot{x}_3 = u_2 \quad (4.23)$$

where

$$x_1 := \lambda_1 \quad (4.24)$$

$$x_2 := l_{os1} \quad (4.25)$$

$$x_3 := \partial l_{os1} / \partial \lambda_1 \quad (4.26)$$

and

$$u_1 := \frac{R_1 \cos \theta_{os1}}{(R_1 + l_{os1})} v_{u1} \quad (4.27)$$

$$u_2 / u_1 := \frac{\partial l_{os1} / \partial \lambda_1}{R_1} \tan \theta_{os1} + \frac{(R_1 + l_{os1})}{R_1 \cos^2 \theta_{os1}} \left\{ \frac{(R_1 + l_{os1}) \tan \delta}{R_1 \cos \theta_{os1} l_1} - \frac{1}{R_1} \right\}. \quad (4.28)$$

ii) When the path-tracking offsets are measured relative to the trailer (and  $c \neq 0$ ), their input-output dynamics can be modeled as

$$\dot{x}_1 = u_1 \quad (4.29)$$

$$\dot{x}_2 = u_1 x_3 \quad (4.30)$$

$$\dot{x}_3 = u_2 \quad (4.31)$$

where

$$x_1 := \lambda_2 \quad (4.32)$$

$$x_2 := l_{os2} \quad (4.33)$$

$$x_3 := \partial l_{os2} / \partial \lambda_2 \quad (4.34)$$

and

$$u_1 := \frac{R_2 \cos \theta_{os2}}{(R_2 + l_{os2})} v_{u2} \quad (4.35)$$

$$u_2 / u_1 := \frac{\partial l_{os2} / \partial \lambda_2}{R_2} \tan \theta_{os2} + \frac{R_2 + l_{os2}}{R_2 \cos^2 \theta_{os2}} \left\{ \frac{(R_2 + l_{os2}) \tan(\beta - \phi)}{R_2 \cos \theta_{os2} l_2} - \frac{1}{R_2} \right\}. \quad 4.36)$$

**Proposition 5 (Path-tracking offsets dynamics and input-output linearization).** By

taking the lateral offset as output, and independently from whether described as a function of time or as a function of distance traveled along the path, the path-tracking offsets dynamics is input-output state-feedback linearizable. Moreover:

i) If the lateral offset is measured relative to the tractor then the input-output linearized model has a zero dynamics that is

asymptotically stable if the path is tracked in the forward direction ( $v_{u1} > 0$ ), unstable if in reverse ( $v_{u1} < 0$ );

ii) If the lateral offset is measured relative to the trailer, then the input-output linearized model has a zero dynamics that is asymptotically stable if the path is tracked in reverse ( $v_{u1} < 0$ ), unstable if in the forward direction ( $v_{u1} > 0$ );

iii) If the hitching of the tractor-trailer is on the axle ( $c=0$ ) then the input-output linearized model obtained when the lateral offset is measured relative to the trailer becomes an input-state linearized model.

**Remark 1.** Eqns (4.5-4.8) were used by DeSantis 1994 for the design of path-tracking controllers using local linearization (see also Togno 1994). Eqns (4.17-4.20) were used by Bolzern et al. 1997 to (heuristically) extend to vehicles with off-axle hitching the (on-axle) approach proposed by Sampei et al. 1995 (see also Masciocchi 1995). When  $c=0$ , eqns (4.17-4.20) become identical to those derived by Sampei et al 1995 and Proposition 5.iii) coincides with the main result given in that reference.

**Remark 2.** When  $c=0$ , Proposition 4.ii) rediscovers the chain-form models considered by Samson 1995 and by Sordalen and Egeland 1995. Indeed, using the notations

$$x_1 := \lambda_2 \tag{4.37}$$

$$x_2 := \ell_{os2} \tag{4.38}$$

$$x_3 := \partial \ell_{os2} / \partial \lambda_2 \tag{4.39}$$

$$x_4 := \partial^2 l_{os2} / \partial \lambda_2^2 \quad (4.40)$$

and

$$u_1 := \frac{R_2 \cos \theta_{os2}}{(R_2 + l_{os2})} v_{u2}. \quad (4.41)$$

$$\begin{aligned} u_2 / u_1 := & \left\{ v_{u2d}^2 \cos^2 \theta_{os1} / (R_2 + l_{os2})^2 \right\} v_{u2} \sin \theta_{os2} \\ & + 2 \left\{ v_{u2d}^2 \cos \theta_{os1} \sin \theta_{os1} / (R_2 + l_{os2})^2 \right\} v_{u2} \left\{ \frac{-\tan(\phi)}{l_2} - \frac{\cos \theta_{os2}}{(R_2 + l_{os2})} \right\} \\ & - v_{u1} \left\{ v_{u2d}^2 \cos \theta_{os1} / (\cos^2 \phi l_2) \right\} \left\{ \frac{l_1 \sin \phi + l_2 \tan \delta}{l_1 l_2} \right\} \end{aligned} \quad (4.42)$$

eqns (4.29-4.36) become

$$\dot{x}_1 = u_1 \quad (4.43)$$

$$\dot{x}_2 = u_1 x_3 \quad (4.44)$$

$$\dot{x}_3 = u_1 x_4 \quad (4.45)$$

$$\dot{x}_4 = u_2 \quad (4.46)$$

These equations correspond to the form considered in Samson 1995. By interchanging the role of  $x_2$  and  $x_4$  we have

$$\dot{x}_1 = u_1 \quad (4.47)$$

$$\dot{x}_2 = u_2 \quad (4.48)$$

$$\dot{x}_3 = u_1 x_2 \quad (4.49)$$

$$\dot{x}_4 = u_1 x_3 \quad (4.50)$$

which corresponds to the form considered by Sordalen and Egeland 1995.

**Remark 3.** In analogy to the on-axle case (Sampei et al. 1995, Samson 1995), Proposition 5 suggests that a path-tracking controller for the off-axle case be designed by taking the lateral path-tracking offset



as output and by using exact linearization. However, for the linearization technique to be effective in this latter case, the location of the guide-point must now depend on the direction of motion: on the tractor when path-tracking has to be implemented in a forward direction (where the tractor is pulling the trailer); on the trailer when in reverse (where the tractor is pushing the trailer). A typical design procedure is illustrated in the next section.

## 5. Path-tracking control Design

### 5.1. Controller Design for Path-tracking in Reverse.

The tractor's longitudinal speed is selected as

$$v_{u1} = v_{u2d} \left( \cos\phi - \frac{c \tan\delta}{l_2} \sin\phi \right)^{-1} . \quad (5.1)$$

From eqn (3.9) it follows  $v_{u2} = v_{u2d}$  and therefore  $v_{os2} = 0$ .

To determine the steering control we derive eqn (4.9) to obtain

$$\ddot{\theta}_{os2} = v_{u2d} \sin\theta_{os2} + v_{u2d} \cos\theta_{os2} \dot{\theta}_{os2} , \quad (5.2)$$

where

$$\dot{v}_{u2d} = \frac{\partial v_{u2d}}{\partial \lambda_2} v_{u2d} . \quad (5.3)$$

Since

$$\dot{\theta}_{os2} = v_{u2d} \left\{ \frac{\tan(\beta - \phi)}{l_2} - \frac{\cos\theta_{os2}}{(R_2 + l_{os2})} \right\} \quad (5.4)$$

it follows

..

$$\ell_{os2} = \alpha_2 + \beta_2 \tan(\beta - \phi) \quad (5.5)$$

where

$$\alpha_2 := v_{u2d} \sin \theta_{os2} - \frac{v_{u2d}^2 \cos^2 \theta_{os2}}{(R_2 + \ell_{os2})} \quad (5.6)$$

and

$$\beta_2 := \frac{v_{u2d}^2 \cos^2 \theta_{os2}}{\ell_2} \quad (5.7)$$

By setting  $\delta = \text{atan}(-\ell_1 \tan \beta / c)$  where  $\beta$  is such that

$$\tan(\beta - \phi) = \beta_2^{-1} (v - \alpha_2), \quad (5.8)$$

and

$$v := -k_1 \ell_{os2} - k_2 \dot{\ell}_{os2} - k_3 \int \ell_{os2} dt \quad (5.9)$$

with  $k_i > 0$ ,  $i=1,2,3$ , it follows

$$\ddot{\ell}_{os2} + k_1 \dot{\ell}_{os2} + k_2 \ell_{os2} + k_3 \int \ell_{os2} dt = 0. \quad (5.10)$$

This latter equation implies

$$\lim_{t \rightarrow 0} \ell_{os2} = 0, \quad \lim_{t \rightarrow 0} \theta_{os2} = 0, \quad \text{and} \quad \lim_{t \rightarrow 0} \tan(\beta - \phi) = -\ell_2 / R_2. \quad (5.11)$$

The (asymptotically stable) zero dynamics associated with this controller is then described by

$$\dot{\phi}_{os2} = v_{u2} \left\{ \frac{R_2 \sin \phi - (c + \ell_2 \cos \phi)}{c R_2} \right\} \quad (5.12)$$

where  $\phi = \phi_d + \phi_{os1}$ , with  $\phi_d$  the solution of

$$R_2 \sin \phi_d = c + \ell_2 \cos \phi_d. \quad (5.13)$$

## 5.2. Controller Design for Forward Path-tracking

We set  $v_{u1} = v_{u1d}$  so that  $v_{os1} = 0$ . To determine the steering action

we derive eqn (4.5) to obtain

$$\dot{l}_{os1} = v_{uld} \sin \theta_{os1} + v_{uld} \cos \theta_{os1} \dot{\theta}_{os1}, \quad (5.14)$$

where

$$\dot{v}_{uld} = \frac{\partial v_{ulp}}{\partial \lambda_1} v_{uld}. \quad (5.15)$$

Since

$$\dot{\theta}_{os1} = v_{ul1} \left\{ \frac{\tan \delta}{l_1} - \frac{\cos \theta_{os1}}{(R_1 + l_{os1})} \right\}, \quad (5.16)$$

it follows

$$\dot{l}_{os1} = \alpha_1 + \beta_1 \tan \delta, \quad (5.17)$$

where

$$\alpha_1 := v_{uld} \sin \theta_{os1} + \frac{v_{uld}^2 \cos^2 \theta_{os1}}{(R_1 + l_{os1})} \quad (5.18)$$

and

$$\beta_1 := \frac{v_{uld}^2 \cos^2 \theta_{os1}}{l_1}. \quad (5.19)$$

By setting

$$\delta = \text{atan}(\beta_1^{-1}(v - \alpha_1)) \quad (5.20)$$

where

$$v := -k_1 l_{os1} - k_2 \dot{l}_{os1} - k_3 \int l_{os1} dt \quad (5.21)$$

with  $k_i > 0$ ,  $i = 1, 2, 3$ , it follows

$$l_{os1} + k_1 l_{os1} + k_2 \dot{l}_{os1} + k_3 \int l_{os1} dt = 0. \quad (5.22)$$

This last equation implies

$$\lim_{t \rightarrow 0} \ell_{os1} = 0, \quad \lim_{t \rightarrow 0} \theta_{os1} = 0, \quad \text{and} \quad \lim_{t \rightarrow 0} \tan \delta = -\ell_1/R_1. \quad (5.23)$$

The (asymptotically stable) zero dynamics associated with this controller is given by

$$\dot{\phi}_{os1} = -v_{uld} \left\{ \frac{R_1 \sin \phi - (\ell_2 + c \cos \phi)}{c R_1} \right\} \quad (5.24)$$

where  $\phi = \phi_d + \phi_{os1}$  with  $\phi_d$  the solution of

$$R_1 \sin \phi_d = \ell_2 + c \cos \phi_d. \quad (5.25)$$

## 6. An Application Example

To facilitate comparisons between the design procedure developed in the previous section and the present state of the art, we revisit the path-tracking controller design considered in DeSantis 1994. The tractor-trailer has geometric parameters  $c = 1\text{m}$ ,  $\ell_1 = 2\text{m}$ ,  $\ell_2 = 4\text{m}$ ; the task is of having the vehicle follow a circle with radius  $R_1 = 20\text{m}$  with a longitudinal speed  $v_{uld} = 2.5 \text{ ms}^{-1}$ .

Because of the non zero value of  $c$ , the vehicle dynamics is not input-state linearizable and a path-tracking controller capable of carrying out this assignment cannot be designed by applying current exact linearization procedures (including, for example, the procedures described in Sampei et al. 1995 and in Samson 1995). It follows that, at the present time, the design has to be carried out by adopting tangent linearization (DeSantis 1994), (heuristically) extended exact linearization (Bolzern et al. 1997), or other

heuristic approaches such as the fuzzy and neural network approach (Kosko 1992, pp. 352-361).

The interest of Propositions 3, 4 and 5 is that they establish the dynamics of the vehicle to be input-output linearizable and that the desired controller can be designed by exploiting this property. In agreement with these results, when the circle has to be tracked in the forward direction we compute tractor's speed and steering in terms of path-tracking offsets measured relative to the tractor. Following the development in section 5.2, the controller is then defined by

$$v_{u1} = v_{u1d} \quad (6.1)$$

$$\delta = \tan^{-1} \{ \beta_1^{-1} (v - \alpha_1) \} \quad (6.2)$$

where

$$\alpha_1 := v_{u1d} \sin \theta_{os1} + \frac{v_{u1d}^2 \cos^2 \theta_{os1}}{(R_1 + l_{os1})}, \quad (6.3)$$

$$\beta_1 := \frac{v_{u1d}^2 \cos^2 \theta_{os1}}{l_1}, \quad (6.4)$$

and

$$v := -k_1 l_{os1} - k_2 l_{os1}. \quad (6.5)$$

Gains  $k_1$  and  $k_2$  are chosen so that the poles  $p_1$  and  $p_2$  characterizing the lateral offset dynamics have a prescribed value. Choosing  $p_1 = p_2 = -.5$ , from

$$s^2 + k_2 s + k_1 = (s - p_1)(s - p_2) \quad (6.6)$$

we have

$$k_1 = p_1 p_2 = .25 \quad (6.7)$$

$$k_2 = -p_1 - p_2 = 1. \quad (6.8)$$

When the circle has to be tracked in reverse, tractor's speed and steering are computed in terms of path-tracking offsets measured relative to the trailer. Following section 5.1, the controller is now defined by

$$v_{u1} = v_{u2d} \left( \cos\phi - \frac{c \tan\delta}{l_2} \sin\phi \right)^{-1} \quad (6.10)$$

$$\delta = \tan^{-1} \left\{ -(\ell_1/c) \tan\beta \right\} \quad (6.11)$$

where

$$\beta = \phi + \tan^{-1} \left\{ \beta_2^{-1} (v - \alpha_2) \right\} \quad (6.12)$$

$$\alpha_2 := v_{u2d} \sin\theta_{os2} + \frac{v_{u2d}^2 \cos^2\theta_{os2}}{(R_2 + \ell_{os2})} \quad (6.13)$$

$$\beta_2 := \frac{v_{u2d}^2 \cos^2\theta_{os2}}{\ell_2} \quad (6.14)$$

and

$$v := -k_1 \ell_{os2} - k_2 \ell_{os2}. \quad (6.15)$$

Gains  $k_1$  and  $k_2$  are determined by following the same argument as in the case of the forward direction and can once again be taken as  $k_1 = .25$ ,  $k_2 = 1$ .

Figures 3 and 4 illustrate the transient behavior induced by the designed controller in correspondence to a typical path-tracking maneuver in reverse. These and similar results (not reported herein) suggest this behavior to be characterized by a region of convergence that is considerably larger and a convergence speed that is

considerably faster than those obtained using a controller based either on classical tangent linearization (DeSantis 1994) or on extended input-state exact linearization (Bolzern et al. 1997), or on the fuzzy and neural network approach (Kosko 1992, pp. 352-361).

It should be noted that while we have chosen to specify the dynamics of this behavior in the time domain (as it is usually done) by applying Proposition 3 only a minor modification in the design procedure would be required to specify it instead as a function of distance traveled along the path (as proposed in Sampei et al 1995 and in Samson 1995). Too, while we have confined ourselves to geometric path-tracking, again only a minor modification in the design procedure would be required to consider instead path-tracking in the sense of state-trajectory-following (as for example, in D'Andrea -Novel et al. 1992 or in Walh et al. 1994)).

## Conclusions

The controller obtained by following the procedure proposed in the present paper can be viewed as a generalized version of the controllers for car-like vehicles, or for tractor-trailer-like vehicles with 'on-axle' hitching, that are currently provided by the exact input-state linearization approach (in Sampei et al. 1995, or in Samson 1995). As in the case of these latter vehicles, a controller for a tractor-trailer with 'off-axle' hitching may be given a structure made of an inner loop with the function of linearizing and decoupling the plant, in parallel with an outer loop

consisting of a classical PID. Within reasonable hypotheses, these results, which have been obtained by confining attention to the kinematics of the vehicle, remain valid if dynamic behaviour is also taken into account (the modalities for carrying out such a validation would be identical to those considered in DeSantis 1994).

The computations to be carried out by the proposed controller, while already relatively simple, can be further simplified without significantly deteriorating performance. Measurements and actions required for a practical implementation can be provided by industrial sensors and actuators that have already been proven adequate for the task, and which begin to be available at a reasonable cost (Juneau et al. 1994, Lane and King 1994, Feng et al. 1994, Sampei et al. 1995, Durrant-Whyte 1996, Piotte et al. 1997, Parkinson 1997).

These conclusions, arrived at in the context of a tractor-trailer with off-axle hitching, are equally applicable to industrial vehicles with equivalent geometric properties as, for example, a tractor with multiple trailers and one or more off-axle hitchings, a load-haul-dump mining truck, an industrial lawn mower, as well as a variety of snow-removal, earth-removal, and road-paving vehicles.



## References

- Cox, I., J., Wilfong, G. T. 1990 (Editors). **Autonomous Robot Vehicles**, Springer-Verlag.
- Baiden, G., Henderson, E. 1994. LHD Teleoperation and Guidance: Proven Productivity Improvement Tools, **6th Canadian Symposium on Mining Automation**, October 16-19, Montreal, pp. 77-87.
- Bolzern, P., DeSantis, R.M., Locatelli, A., Togno, S. 1996. Dynamic Model of a Two-Trailer Articulated Vehicle Subject to Nonholonomic Constraints, **Robotica**, Vol. 14, 1996, pp. 445-450.
- Bolzern, P., DeSantis, R.M., Locatelli, A., Masciocchi, D. 1997. Path-Tracking for Articulated Vehicles with Off-Axle Hitching, **IEEE Trans on Control Systems Technology** (to appear).
- D'Andrea-Novel, B., Bastin, G., Campion, G. 1992. Dynamic Feedback Linearization of Nonholonomic Wheeled Mobile Robots, **Proc. of the 1992 ICRA Conference**, Nice, France, pp. 2527-2530.
- Dasys, A., Drouin, A., Geoffry, L., Teaching an LHD to Muck, **6th Canadian Symposium on Mining Automation**, October 16-19, Montreal, pp. 87-94.
- DeSantis, R.M. 1994. Path-Tracking for Tractor-Trailer-like Robots, **Int. Journal of Robotic Research**, Vol 13, N.3, 1994, pp 533-544.
- DeSantis, R.M. 1997. Modeling and Path-Tracking for a Load-Haul-Dump Vehicle, **Trans of the ASME Journal of Dynamic Systems Measurement and Control**, Vol. 119, march 1977, pp. 40-47.
- Durrant-Whyte, H.F. 1996. An Autonomous Guided Vehicle for Cargo Handling Applications, **Int. Journal of Robotic Research**, Vol 15, N.5, 1996, pp. 407-440.
- Ellis, J.R. 1969. **Vehicle Dynamics**, London, London Business Books.
- Feng, L., Borenstein, J., Everett, H.R. 1994. **Where Am I? Sensors and Methods for Autonomous Mobile Robot Positioning**, T.R. UM-MEAM-94-21, Univ. Michigan, Ann Arbor, 1994.
- M. Fliess, J. Lévine, P. Martin, P. Rouchon 1995. Flatness and defect of nonlinear systems: introductory theory and examples, **Int. J. Control**, vol.61, pp.1327-1361.
- Giralt, G. 1988. **Les Robots Mobiles Autonomes**, LAAS, Toulouse, Publication No. 87308.
- Kosko, B. 1992. **Neural Networks and Fuzzy Systems**. Prentice Hall, Inglewood Cliffs.
- Hurteau, R., St-Amant, M., Laperriere, Y., Chevrette, G. 1992. Optical Guidance System for Underground Vehicles, **1992 IEEE Int. Conference on Robotics and Automation**, Nice, France, pp. 639-644.
- Hilrose S., Fukushima, E.F., Tsukagoshi, S. 1995. Basic steering control methods for the articulated body mobile robot, **IEEE Control Systems**, February 1995, pp. 5-14, 1995.
- Isidori, A. 1995. **Nonlinear Control Systems**, Springer-Verlag, London.
- Juneau, L., Hurteau, R. 1994. Automatic Guidance of a Mining Vehicle Using Laser Range Data: Simulation and Preliminary Experimental Results, **Proc. of the 5th International Symposium on Robotics and Manufacturing**, Hawaii, USA, Aug 1994, pp. 545-550.
- Khalil, H.K. 1992. **Nonlinear Systems**, MacMillan Pub. Co., New York.
- Kumar, D., Vagenas, N. 1993. Performance Evaluation of an Automatic Load-Haul-Dump Vehicle, **CIM Bulletin**, Vol. 86, N. 974, October 1993, pp. 39-42.
- Lane, J.D., King, R.H. 1994. Computer Assisted Guidance of an Underground Mine Truck, **1994 IEEE Int. Conference on Robotics and Automation**, San Francisco, Cal, pp. 420-425.

- Larsson, U., Zell, C., Hyppa, K., Wernesson, A. 1994. Navigating an Articulated Vehicle and Reversing with a Trailer, **1994 IEEE Int. Conference on Robotics and Automation**, San Francisco, Cal, pp. 2398-2404.
- Laumond, J.P. 1993. Controllability of a Multibody Mobile Robot, **IEEE Trans on Robotics and Automation**, Vol. 9, N.6, December 1993, pp. 755-763.
- Marino, R., Tomei, P. 1996. **Nonlinear Control Design: Geometric, Adaptive, Robust**, London, Prentice Hall, 1996.
- Masciocchi, D., Tecniche di Controllo Nonlineare per la Guida Automatica di Veicoli Articolati, Tesi di Laurea di Dottore in Ingegneria Informatica, **Politecnico di Milano**, March 1995.
- Piotte, M., et al. 1997. Automatic Control of Underground Vehicles at High Speeds, **CIM Bulletin**, Vol.90, N. 1006, January 1997, pp 78-81.
- Rabinovitch, J., Leitman, J., Urban Planning in Curitiba, **Scientific American**, Vol.274, N.3, March 1996, pp. 46-53.
- Sampei, M., Tamura, T., Kobayashi, T., Shibui, N. 1995. Arbitrary Path-Tracking Control of Articulated Vehicles Using Nonlinear Control Theory, **IEEE Trans. on Control Systems Technology**, Vol.3, N.1, March 1995, pp. 125-131.
- Samson, C., 1995. Control of Chained Systems Application to Path Following and Time Varying Point-Stabilization of Mobile Robots, **IEEE Trans. on Automatic Control**, Vol. 40, N.1, January 1995, pp. 64-77.
- Shin, D.H., Singh, S., Lee, J.J., Explicit Path Tracking by Autonomous Vehicles, **Robotica**, Vol. 16, pp. 537-554, 1992.
- Sordalen, O.J., Egeland O., Exponential Stabilization of Nonholonomic Chained Systems, **IEEE Trans. on Automatic Control**, Vol.40, N.1, January 1995, pp.35-49.
- Tilbury, D., Murray, R.M., Sastry, S.S., 1995. Trajectory Generation for the N-Trailer Problem Using Goursat Normal Form, **IEEE Trans. on Automatic Control**, Vol. 40, N.5, May, pp. 802-819.
- Togno, S., Sintesi di un Controllore per la Guida Automatica di un Veicolo Articolato, Tesi di Laurea di Dottore in Ingegneria Informatica, **Politecnico di Milano**, March 1994.
- Walsh, G., Tilbury, D., Sastry, S., Murray, R., Laumond, J.P. 1994. Stabilization of Trajectories for Systems with Nonholonomic Constraints, **IEEE Trans. on Automatic Control**, Vol. 39, N.1, January, pp. 216-222.

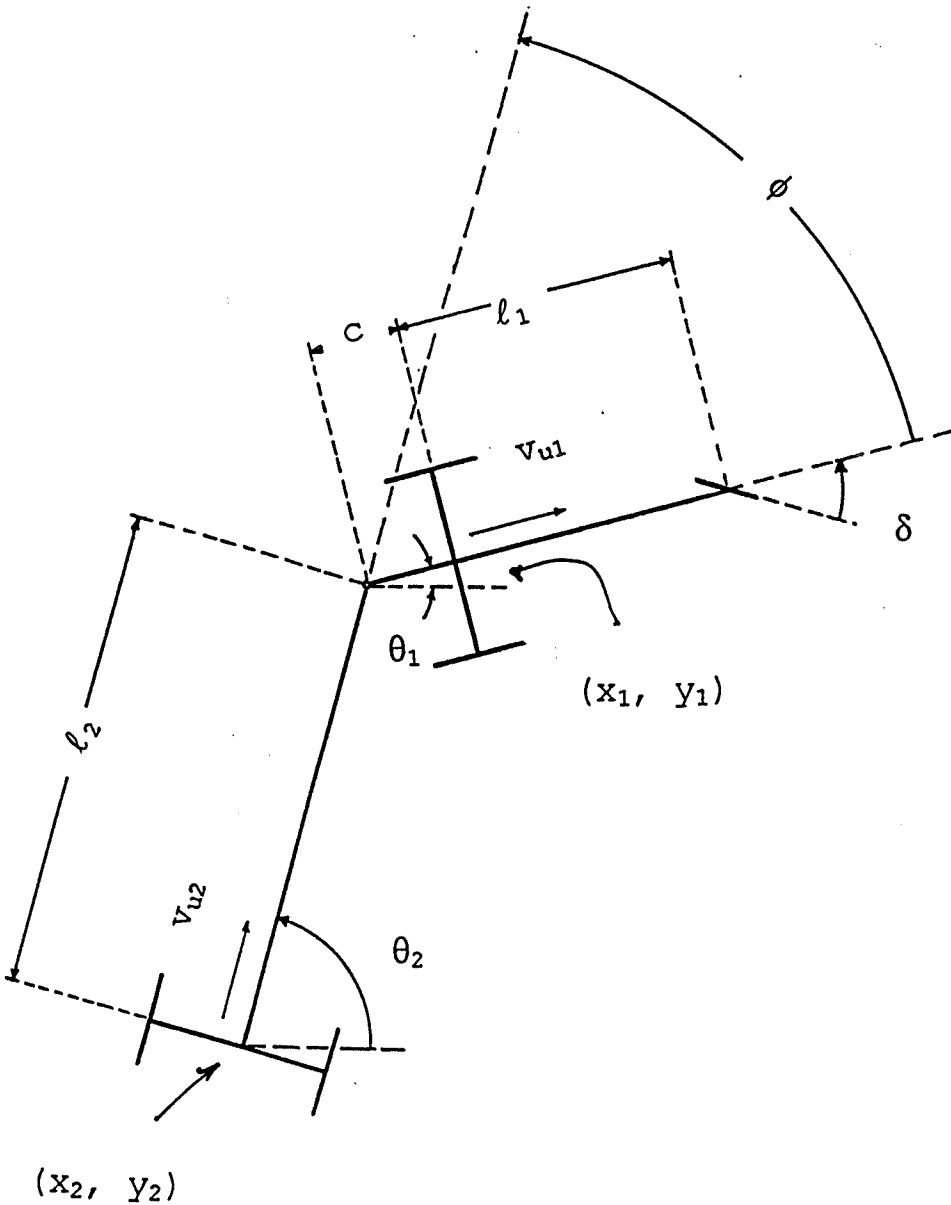

Figure 1: Vehicle's geometry

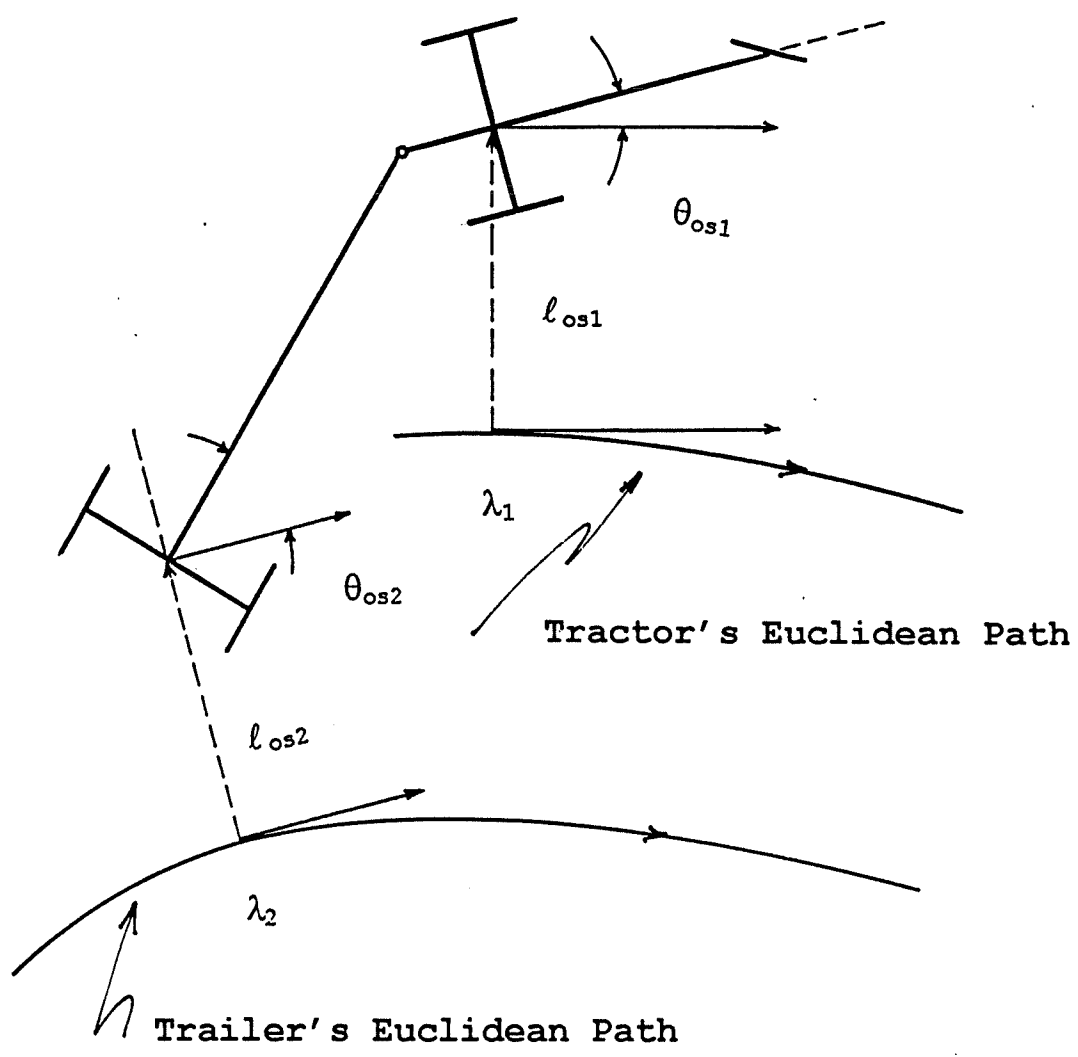

Figure 2: Path-tracking offsets

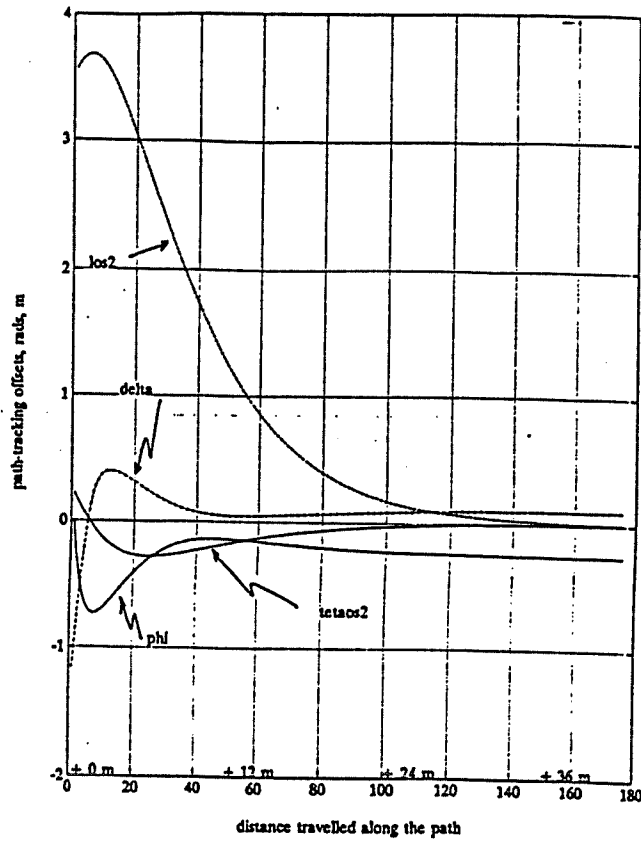

Figure 3: Path-tracking offsets temporal dynamics

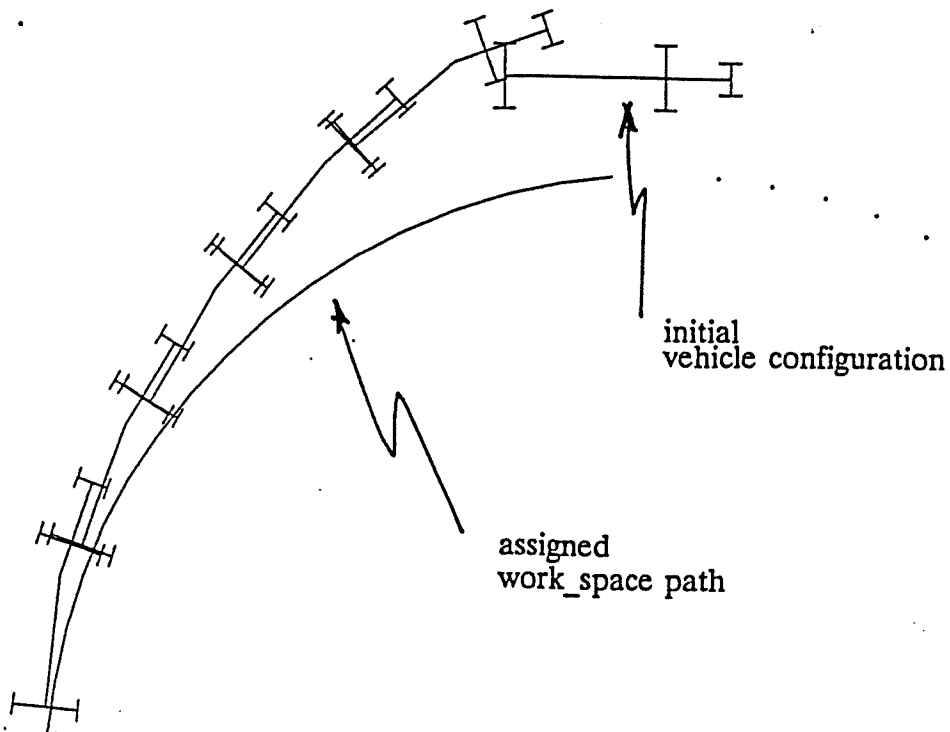

Figure 4: Path-tracking offsets dynamics in operational space

## APPENDIX: Outline of proofs

**Proposition 1.** Eqns (3.1-3.5) are well-known and can be written down by a direct inspection of Figure 1 (see for example Ellis 1969). To verify the validity of eqns (3.7-3.12), note that angle  $\beta$  represents the orientation relative to the tractor of the velocity vector at the point common to the trailer and to the tractor;  $\beta-\phi$  represents the measure of this same orientation relative to the trailer. Note that  $\beta-\phi$  plays, with respect to the trailer, the same role that the steering angle  $\delta$  plays with respect to the tractor. It follows that eqns (3.7-3.12) can be obtained using the same argument as for eqns (3.1-3.6), by replacing  $\delta$  with  $\beta-\phi$  and by replacing  $l_1$   $l_2$  and  $c$  respectively with  $l_2$   $c$  and (again)  $l_2$ .

**Proposition 2.** Eqns (4.5) is obtained by deriving

$$l_{os} := -\{x-x_d\}\sin\theta_d + \{y-y_d\}\cos\theta_d, \quad (\text{a.1})$$

and by taking into account that the vector  $(\{x-x_d\}, \{y-y_d\})$  is perpendicular to the tangent to the path at  $(x_d, y_d)$ . Eqn (4.6) follows by observing that

$$\dot{\theta}_{os1} = v_{u1}\tan\delta/l_1 - \frac{\partial\theta_p}{\partial s} \Big|_{s=\lambda_1} \dot{\lambda}_1 \quad (\text{a.2})$$

where

$$\frac{\partial\theta_p}{\partial s} \Big|_{s=\lambda_1} = 1/R_1 \quad (\text{a.3})$$

and

$$\dot{\lambda}_1 = \frac{R_1 \cos \theta_{os1}}{(R_1 + l_{os1})} v_{u1}. \quad (a.4)$$

Eqn (4.7) follows from eqn (3.4) and the fact that when tracking a straight line or a circular path the value of  $\phi = \phi_d$  must be constant and such as to satisfy eqn (4.8). Eqns (4.9-4.11) are obtained by proceeding as for eqns (4.5-4.8) by once again interchanging the roles play by the tractor and the trailer. In particular  $\delta$  is replaced with  $\beta - \phi$ ;  $l_1$ ,  $l_2$  and  $c$  respectively with  $l_2$ ,  $c$  and (again)  $l_1$ .

**Proposition 3.** Eqns (4.13-4.15) follow by recognizing that  $\dot{\lambda}_1$ , the longitudinal speed of the tractor relative to the path is indeed given by eqn (4.16) and by observing that for  $f \in \{l_{os1}, \theta_{os1}, \phi_{os1}\}$  we have  $\partial f / \partial \lambda_1 = \dot{f} / \dot{\lambda}_1$ , where  $f$  is as specified in eqns (4.5-4.7). Eqns (4.17-4.19) follow in the same manner by interchanging the role of tractor and trailer.

**Proposition 4.** The proof follows by a direct inspection by taking into account Proposition 3.

**Proposition 5. i)** By choosing  $v_{u1} = v_{u1d}$ , by twice deriving  $l_{os1}$  and by using eqn (4.6), we have

$$\dot{l}_{os1} = v_{u1d} \sin \theta_{os1}, \quad (a.5)$$

$$\ddot{l}_{os1} = v_{u1d}^2 \cos \theta_{os1} \left\{ \tan \delta / l_1 - \cos \theta_{os1} / (R_1 + l_{os1}) \right\} \quad (a.6)$$

Introducing the new control

$$u := v_{u1d}^2 \cos \theta_{os1} \left\{ \tan \delta / l_1 - \cos \theta_{os1} / (R_1 + l_{os1}) \right\} \quad (a.7)$$

it follows

$$\ddot{l}_{os1} = u. \quad (a.8)$$

The zero dynamics associated with this input-output model (Marino and Tomei 1996) is described by

$$\dot{\phi}_{os1} = -v_{u1d} \left\{ \frac{R_1 \sin(\phi_d + \phi_{os1}) + l_2 + c \cos(\phi_d + \phi_{os1})}{l_2 R_1} \right\} \quad (a.9)$$

where  $\phi_d$  is such that  $\phi_{os1}=0$  is the equilibrium point, that is such that

$$R_1 \sin(\phi_d) + l_2 + c \cos(\phi_d) = 0. \quad (a.10)$$

By applying Lyapunov indirect method (Khalil 1992) and assuming  $R_1 \cos(\phi_d) + c \sin(\phi_d) > 0$ , it follows that the equilibrium point of the zero dynamics is asymptotically stable when  $v_{u1d} > 0$ , unstable when  $v_{u1d} < 0$ .

ii). By selecting

$$v_{u1} = v_{u2d} \left( \cos \phi - \frac{c \tan \delta}{l_1} \sin \phi \right)^{-1} \quad (a.11)$$

we have  $v_{u2} = v_{u2d}$ . By twice deriving  $l_{os2}$  we get

$$\ddot{l}_{os2} = v_{u2d}^2 \cos \theta_{os1} \left\{ \tan(\beta - \phi) / l_2 - \cos \theta_{os2} / (R_2 + l_{os2}) \right\}, \quad (a.12)$$

and by introducing the new control

$$u = v_{u2d}^2 \cos \theta_{os1} \left\{ \tan(\beta - \phi) / l_2 - \cos \theta_{os2} / (R_2 + l_{os2}) \right\} \quad (a.13)$$

we obtain

$$\ddot{l}_{os2} = u. \quad (a.14)$$



The zero dynamics associated with this linear model is described by

$$\dot{\phi}_{os2} = -v_{u2d} \left\{ \frac{R_2 \sin(\phi_d + \phi_{os2}) + c + l_2 \cos(\phi_d + \phi_{os2})}{cR_2} \right\} \quad (a.15)$$

where  $\phi_{os2} = 0$  is the equilibrium point and  $\phi_d$  satisfies the equation

$$R_2 \sin(\phi_d) + c + l_2 \cos(\phi_d) = 0. \quad (a.16)$$

By proceeding as in i) and assuming  $R_2 \cos(\phi_d) + l_2 \sin(\phi_d) > 0$ , the equilibrium point of this zero dynamics is found to be asymptotically stable when  $v_{u1d} < 0$ , unstable when  $v_{u1d} > 0$ .

iii). With the hitching on the axle we have  $c=0$  and therefore  $\beta=0$ .

It follows from eqn (a.12 )

$$\ddot{l}_{os2} = v_{u2d}^2 \cos\theta_{os1} \left\{ -\tan(\phi) / l_2 - \cos\theta_{os2} / (R_2 + l_{os2}) \right\} \quad (a.17)$$

and by deriving with respect to time

$$\begin{aligned} \dots \\ \dot{l}_{os2} = & \left\{ v_{u2d}^2 \cos\theta_{os1}^2 / (R_2 + l_{os2})^2 \right\} \dot{l}_{os2} \\ & + 2 \left\{ v_{u2d}^2 \cos\theta_{os1} \sin\theta_{os1} / (R_2 + l_{os2})^2 \right\} \dot{\theta}_{os2} + \left\{ v_{u2d}^2 \cos\theta_{os1} / (\cos^2\phi l_2) \right\} \dot{\phi}_{os2}. \end{aligned} \quad (a.18)$$

By invoking eqns (4.9) and (4.10), by observing  $c=0$  implies

$$\dot{\phi}_{os1} = -v_{u1} \left\{ \frac{l_1 \sin\phi + l_2 \tan\delta}{l_1 l_2} \right\}, \quad (a.19)$$

and by introducing the new control variable

$$\begin{aligned} u = & \left\{ v_{u2d}^2 \cos\theta_{os1}^2 / (R_2 + l_{os2})^2 \right\} v_{u2} \sin\theta_{os2} \\ & + 2 \left\{ v_{u2d}^2 \cos\theta_{os1} \sin\theta_{os1} / (R_2 + l_{os2})^2 \right\} v_{u2} \left\{ \frac{-\tan(\phi)}{l_2} - \frac{\cos\theta_{os2}}{(R_2 + l_{os2})} \right\} \end{aligned}$$

$$- v_{u1} \left\{ v_{u2d}^2 \cos \theta_{os1} / (\cos^2 \phi l_2) \right\} \frac{l_1 \sin \phi + l_2 \tan \delta}{l_1 l_2} \quad (a.20)$$

it follows

$$\ddot{l}_{os2} = u. \quad (a.21)$$

The state of this linear model  $(l_{os2} \dot{l}_{os2} \ddot{l}_{os2})$  is equivalent to the state  $(l_{os2} \theta_{os2} \phi_{os2})$  of the original plant model.

**Symbols**

=====

$(x_1, y_1)$ : work-space coordinates of the tractor's guide-point;

$(x_2, y_2)$ : work-space coordinates of the trailer's guide-point;

$\theta_1, \theta_2$ : tractor's, trailer's heading;

$\phi$ : trailer's orientation with respect to the tractor;

$\delta$ : steering angle;

$\lambda_1, \lambda_2$ : distance traveled along the path;

$l_{os1}, l_{os2}$  : path-tracking lateral offsets measured relative to  
respectively the tractor and the trailer;

$v_{u1}, (v_{u2})$ : tractor's (trailer's) longitudinal velocity;

$c$ : distance from tractor's rear-axle to vertical joint;

$l_1$ : distance from tractor's rear axle to front axle;

$l_2$ : distance from trailer's axle to vertical joint;

$\beta := -\text{atan}(\text{ctan}\delta/l_1)$ : angle of orientation relative to the tractor of the  
velocity vector at the articulated joint;

$v_{u1d}, v_{u2d}$  : desired velocities of the vehicle's guide-points;

$v_{os1}, v_{os2}$ : speed offsets;

$\theta_{os1}, \theta_{os2}, \phi_{os}$  : heading offsets;

$R_1, R_2$  : radius of the circular path;

ÉCOLE POLYTECHNIQUE DE MONTRÉAL  
  
3 9334 00171563 8

École Polytechnique de Montréal  
C.P. 6079, Succ. Centre-ville  
Montréal (Québec)  
H3C 3A7

